

Name of Material	:	Closer - HDPE - PCO 1810
Manufacturer	:	NA
Supplier	:	NA
Country of Origin	:	NA
Batch/Lot No.	:	NA
MFG Date	:	NA
EXP Date	:	NA
Challan No.	:	NA
QA Ref. No.	:	NA
QRN Ref. No.	:	NA
Qty. Supplied	:	NA
Date of Received	:	NA
Date of Testing	:	NA
Date of Reporting	:	NA

SN	Description	Specification	Results
01	PCO Type	PCO 1810	
02	Shell Material	HDPE	
03	Weight [Total Shell]	As per Design	
04	Height [Outer]	As per Design	
05	Height [Inner]	As per Design	
06	Shell Dia [Outer]	As per Design	
07	Shell Dia [Inner]	As per Design	
08	Shell Weight [Except Lock Ring]	As per Design	
09	Lock Ring Weight	As per Design	
10	Lock Ring Height	As per Design	
11	Lock Ring Bridge Quantity	As per Design	
12	Knurl Quantity	As per Design	
13	Knurl Zero Point Marking	As per Design	
14	Gate Point Position	Middle Aligned	
15	Inner Lock – Inner Dia	As per Design	
16	Inner Lock – Outer Dia	As per Design	
17	Inner Lock – Height	As per Design	

18	Rotational Torque – Clockwise	As per Design	
19	Rotational Torque – Anticlock	As per Design	
20	Color	As per Design	
21	Fiber Thread	As per Design	
22	Top Flat Portion check after locking	Smooth, not broken, not over back pressurized.	
23	Black Particle or Foreign Matter	Absent	
24	Printing Text	As per Design	
25	Printing Color	As per Design	
26	Printing Color Stability	Stable in Tap Test. Stable after locking in filling machine.	

Remarks	
----------------	--

Decision		Accepted		Rejected
-----------------	--	----------	--	----------

.....
Tested By **Checked By** **Approved By**



Other Related Information

Name of Material	Closer - HDPE - PCO 1810	
Others Name	NA	
Chemical Composition	NA	
Molar Mass	NA	
Density	NA	
Melting Point	NA	
Boiling Point	NA	
Others Information	NA	
Function in Food Process	<ul style="list-style-type: none"> - Use as a primary packaging material. - Increase product looking quality. 	

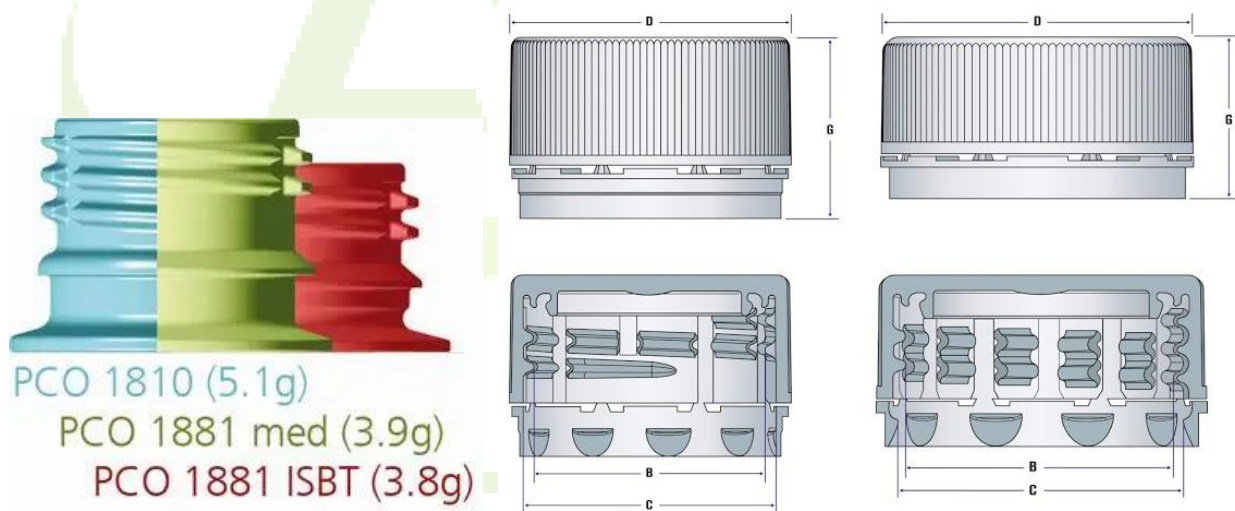

AMEERA
consultancy